



Spare Parts List  
Ersatzteilliste  
Liste de pièces détachées  
Lista de piezas de repuesto

2014-07

ELM4611 (2012)

ELM4611 (2012) (D, GB, F, E)

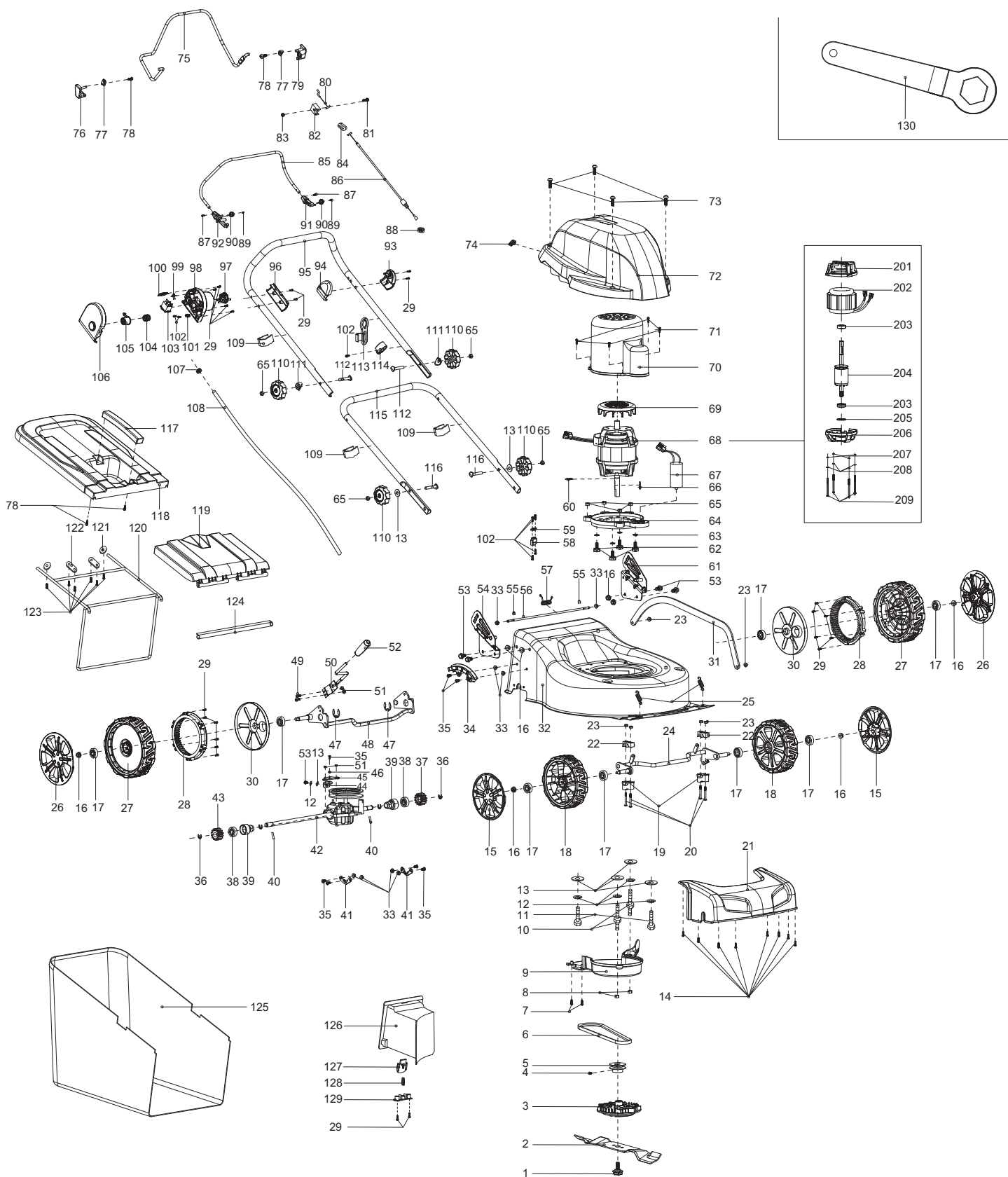

Seite / Page	Pos.	Teil-Nr. Part No. No. de pièce No. de pieza	Hinweise Notes Renseign. Nota	Bezeichnung	Spezifikation Specification	Description	Désignation	Denominación
1	1	671 100 802		MESSERSCHRAUBE	M10x1.35x40	BLADE TIGHTEN BOLT	VIS DE LAME	TORNILLO DE LA CUCHILLA
1	2	671 146 102		MESSER	460X55X3mm	BLADE	LAME	CUCHILLA
1	3	671 005 057		MESSERHALTER		HUB	MOYEU	SOPORTE DE LA CUCHILLA
1	4	671 003 005		INNEN-6KT-SCHRAUBE	M6x8	ALLEN SCREW	BOULON À SIX PANS CREUX	TORNILLO DE CABEZA CON HEX. INTER.
1	5	671 004 009		RIEMENSCHLEIBE	45	PULLEY	POULIE À GORGE POUR COURROIE	DISCO DE LA CORREA
1	6	671 002 043		KEILRIEMEN	Li=752mm, La=790mm	V-BELT	COURROIE TRAPÉZOIDALE	CORREA TRAPEZOIDAL
1	7	671 001 037		SCHRAUBE SELBSTSCHNEIDEND	5x16	SELF-TAPPING SCREW	VIS DE FORAGE	TORNILLO PERFORADOR
1	8	671 005 008		6KT-MUTTER	M8	HEXAGONAL LOCKING NUT	ECROU HEXAGONAL	TUERCA HEXAGONAL
1	9	671 658 001		RIEMENABDECKUNG	with edge cutting	BELT COVER	COUVERCLE DE COURROIE	CUBIERTA DE CORREA
1	10	671 003 044		SPEZIALSCHRAUBE	M8x17x35	SPECIAL SCREW	VIS SPÉCIALE	TORNILLO ESPECIAL
1	11	671 006 017		6KT-SCHRAUBE	M8x30	HEXAGON HEAD BOLT	VIS À SIX PANS	TORNILLO HEXAGONAL
1	12	671 008 002		FEDERRING	φ8	SPRING RING	RONDELLE À RESSORT	ANILLO ELÁSTICO
1	13	671 007 007		SCHEIBE	φ8	WASHER	RONDELLE	ARANDELA
1	14	671 001 062		SCHRAUBE SELBSTSCHNEIDEND	4,2x10	SELF-TAPPING SCREW	VIS DE FORAGE	TORNILLO PERFORADOR
1	15	671 001 176		RADKAPPE	7"	WHEEL COVER	CHAPEAU DE MOYEU	CAPERUZA DE RUEDA
1	16	671 005 028		6KT-MUTTER	M8	HEXAGONAL LOCKING NUT	ECROU HEXAGONAL	TUERCA HEXAGONAL
1	17	671 004 012		KUGELLAGER	6201Z	BALL BEARING	ROULEMENT À BILLES	RODAMIENTO DE BOLAS
1	18	671 002 012		RAD	7"	WHEEL ASSY.	ROUE	RUEDA
1	19	671 418 001		LAGERSCHALE		FIXED BRACKET	COQUILLE DE COUSSINET	MITAD DE RODAMIENTO
1	20	671 002 028		SCHRAUBE	M6x45	TRIGGER BOLT	VIS	TORNILLO
1	21	671 659 001		FRONTTEIL	BLACK with edge cutting	FRONT COVER	PANNEAU	FRONTAL CUBIERTA
1	22	671 445 001		LAGERSCHALE		AXLE SHEATH	PLAQUETTE	COJINETE
1	23	671 005 005		6KT-MUTTER	M6	LOCKING NUT	ECROU	TUERCA
1	24	671 001 786		VORDERACHSE	with edge cutting	FRONT WHEEL AXLE	ESSIEU AVANT	EJE DELANTERO
1	25	671 011 125		ZUGFEDER		EXTENSION SPRING OF FRONT WHEEL AXLE	RESSORT	RESORTE
1	26	671 001 177		RADKAPPE	8"	WHEEL COVER	CHAPEAU DE MOYEU	CAPERUZA DE RUEDA
1	27	671 020 140		RAD	8"	WHEEL ASSY.	ROUE	RUEDA
1	28	671 464 001		ZAHNRAD		TEETH RING	ROUE DENTEE	PIÑÓN
1	29	671 001 005		SCHRAUBE SELBSTSCHNEIDEND	4x16	SELF-TAPPING SCREW	VIS DE FORAGE	TORNILLO PERFORADOR
1	30	671 465 001		RAD-INNENABDECKUNG		INNER WHEEL COVER	CHAPEAU DE MOYEU	CAPERUZA DE RUEDA
1	31	671 144 002		VERBINDUNGSSTANGE	528mm	CONNECTING ROD	BARRE DE RACCORDEMENT	BARRA DE CONEXIÓN
1	32	671 001 527		GEHÄUSE BLAU	18" with edge cutting	DECK BLUE	CHÂSSIS BLEU	CAJA AZUL
1	33	671 005 024		6KT-MUTTER	M6	HEXAGONAL LOCKING NUT	ECROU HEXAGONAL	TUERCA HEXAGONAL

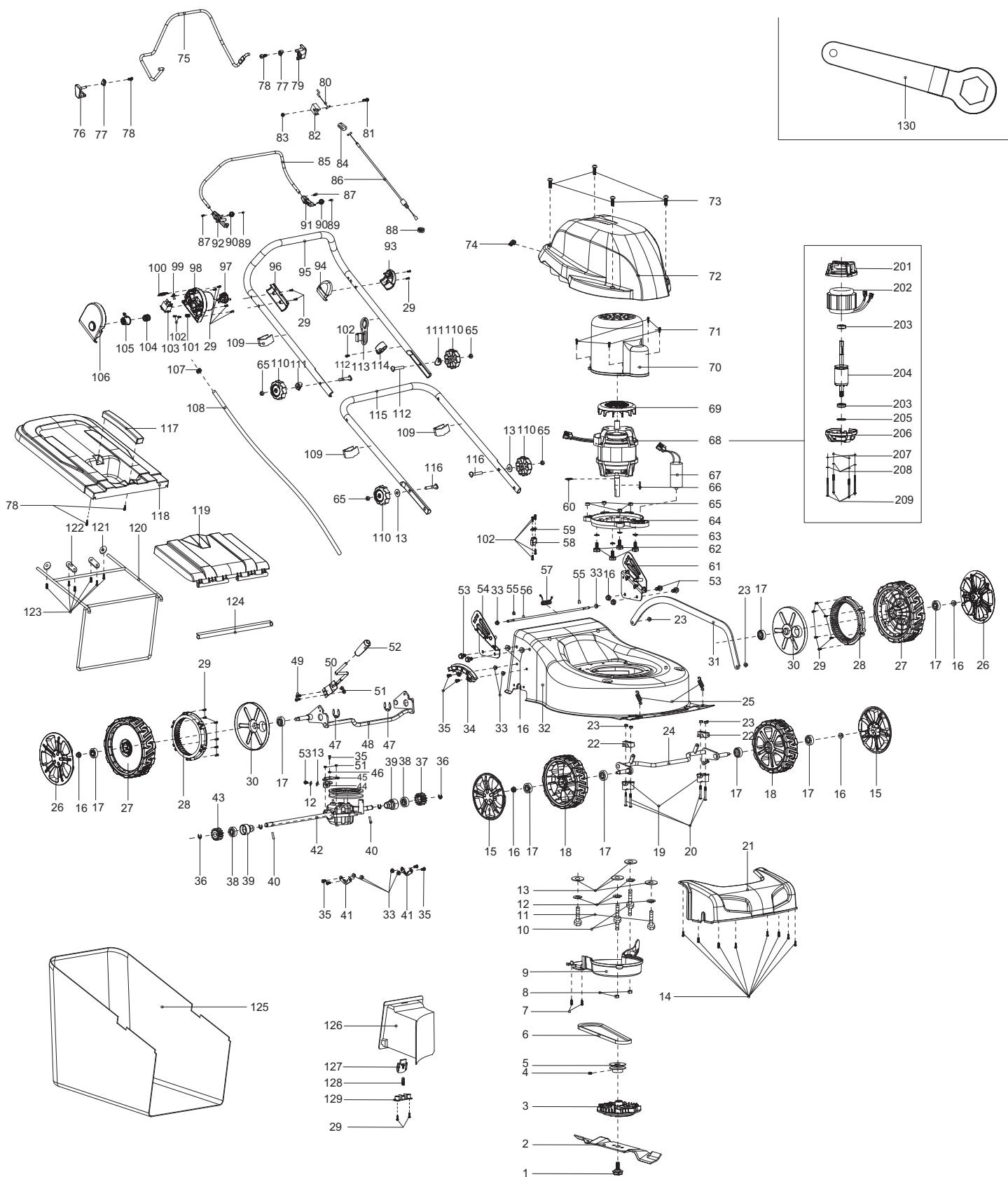

ELM4611 (2012)

1

EM-460 S, ELM4611 (SCHUKO, UK)  
EM-460 S, ELM4611 (SCHUKO, UK)  
EM-460 S, ELM4611 (SCHUKO, UK)  
EM-460 S, ELM4611 (SCHUKO, UK)

Seite / Page	Pos.	Teil-Nr. Part No. No. de pièce No. de pieza	Hinweise Notes Renseign. Nota	Bezeichnung	Spezifikation Specification	Description	Désignation	Denominación
1	34	1 671 001 018		DREHPUNKT FÜR HÖHENVERSTELLU NG		HEIGHT ADJUSTMENT PLATE	POINT DE ROTATION POUR LE RÉGLAGE EN HAUTEUR	PUNTO DE GIRO PARA REGLAJE DE ALTURA
1	35	7 671 002 019		SCHRAUBE	M6x12	TRIGGER BOLT	VIS	TORNILLO
1	36	4 671 090 020		SICHERUNGSSCHEI BE		SAFETY WASHER	RONDELLE SÉCURITÉ	ARANDELA SEGURIDAD
1	37	1 671 003 001		ZAHNRAD, LINKS		GEAR WHEEL, LEFT	ROUE DENTÉE, GAUCHE	PIÑÓN, IZQ.
1	38	2 671 004 023		LAGER		BEARING	ROULEMENT	RODAMIENTO
1	39	2 671 002 035		LAGERGEHÄUSE		BEARING HOUSING	CARTER	CÁRTER
1	40	2 671 090 001		ZYLINDERSTIFT	φ5x21.5	CYLINDRICAL PIN	GOUPILLE CYLINDRIQUE	PASADOR CILINDRICO
1	41	2 671 001 244		FIXIERUNG		RING OF AXLE FIXING	FIXATION	FIJACIÓN
1	42	1 671 502 016		ANTRIEB	self-propelled, with edge cutting	GEAR BOX	GROUPE TRACTION	UNIDAD DE TRACCIÓN
1	42	1 671 011 180		ZUGFEDER	for gear box	TENSION SPRING	RESSORT DE TRACTION	MUELLE DE TRACCIÓN
1	43	1 671 003 002		ZAHNRAD, RECHTS		RIGHT GEAR	ROUE DENTÉE, DROITE	PIÑÓN, DERECHA
1	44	1 671 001 521		BEFESTIGUNGSBLE CH	2	FIXING PLATE	TÔLE DE FIXATION	CHAPA DE FIJACIÓN
1	45	1 671 001 460		BEFESTIGUNGSBLE CH		FIXING PLATE	TÔLE DE FIXATION	CHAPA DE FIJACIÓN
1	46	1 671 008 003		FEDERSCHEIBE	φ6,65	SPRING WASHER	RONDELLE A RESSORT	ARANDELA ELASTICO
1	47	2 671 009 003		SICHERUNGSSCHEI BE	φ19x1.5	SAFETY WASHER	RONDELLE SÉCURITÉ	ARANDELA SEGURIDAD
1	48	1 671 144 602		HINTERRADACHSE KPL.	with edge cutting	REAR AXLE ASSY.	ESSIEU ARRIÈRE CPL.	EJE TRASERO CPL.
1	49	2 671 002 029		SCHRAUBE	M5x12	TRIGGER BOLT	VIS	TORNILLO
1	50	1 671 102 602		HEBEL, HÖHENVERSTELLU NG UND GRIFFUMHÜLLUNG KPL.		LEVER, HEIGHT ADJUSTMENT CPL.	LEVIER, REGLAGE HAUTEUR CPL.	PALANCA, AJUSTE ALTURA CPL.
1	51	4 671 005 011		6KT-MUTTER	M5	HEXAGONAL LOCKING NUT	ECROU HEXAGONAL	TUERCA HEXAGONAL
1	52	1 671 102 602		HEBEL, HÖHENVERSTELLU NG UND GRIFFUMHÜLLUNG KPL.		LEVER, HEIGHT ADJUSTMENT CPL.	LEVIER, REGLAGE HAUTEUR CPL.	PALANCA, AJUSTE ALTURA CPL.
1	53	5 671 006 064		6KT-SCHRAUBE	M8x6	HEXAGON HEAD BOLT	VIS À SIX PANS	TORNILLO HEXAGONAL
1	54	1 671 001 180		GRIFFANBINDUNG, RECHTS	MAKITA BLUE	BRACKET HANDLE, RIGHT	BRIDE DE POIGNÉE, DROITE	FIJACIÓN DE MANGO, DERECHA
1	55	2 671 009 017		KLEMMRING		OPEN BLOCK RING	ANNEAU	ANILLO
1	56	1 671 001 518		STANGE GRASKLAPPE		LONG POLE	TRINGLE TRAPPE À HERBE	BARRA TAPA DE YERBA
1	57	1 671 011 101		FEDER		SPRING OF REAR COVER BOARD	RESSORT	MUELLE
1	58	1 671 260 001		KABELKLEMME		CABLE HOLDER	CRAMP	COLLIER DE SERRAGE
1	59	1 671 001 023		KABELKLEMME		CABLE HOLDER	CRAMP	COLLIER DE SERRAGE
1	60	1 671 009 019		SICHERUNGSRING		SNAP RING	CIRCLIP	ANILLO SEGURIDAD
1	61	1 671 001 179		GRIFFANBINDUNG, LINKS	MAKITA BLUE	BRACKET HANDLE, LEFT	BRIDE DE POIGNÉE, GAUCHE	FIJACIÓN DE MANGO, IZQ.
1	62	4 671 001 009		SCHRAUBE		MOTOR TIGHTEN BOLT	VIS	TORNILLO
1	63	4 671 008 010		ZACKENRING		TOOTHED WASHER	RONDELLE DENTELLEE	ARANDELA DENTADA

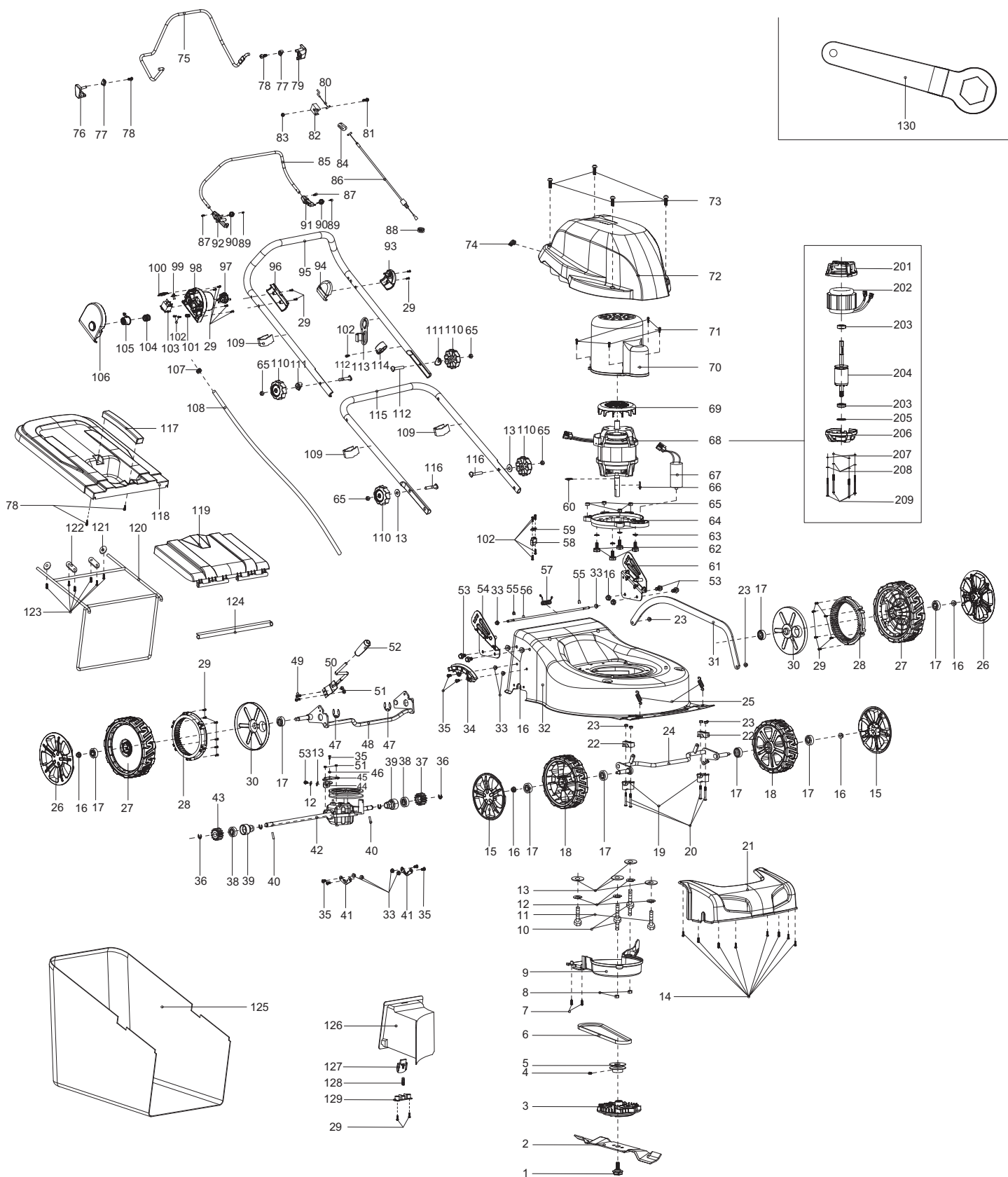

Seite / Page	Pos.	Teil-Nr. Part No. No. de pièce No. de pieza	Hinweise Notes Renseign. Nota	Bezeichnung	Spezifikation Specification	Description	Désignation	Denominación
1	64	1 671 600 012		MOTORTRÄGER		MOTOR BRACKET	SUPPORT DE MOTEUR	SOPORTE DE MOTOR
1	65	8 671 005 007		MUTTER	M8	NUT	ECROU	TUERCA
1	66	1 671 090 037		PASSFEDER		FLAT KEY	CLAVETTE	CHAVETA
1	67	1 671 003 015		KONDENSATOR	25µF	CAPACITOR	CONDENSATEUR	CONDENSADOR
1	68	1 671 002 017		MOTOR	CE/GS,230V~50Hz,1800W	MOTOR	MOTEUR	MOTOR
1	69	1 671 327 001		LÜFTERRAD		FAN	ROUE DE VENTILATEUR	RODETE DEL VENTILADOR
1	70	1 671 461 001		MOTORGEHÄUSE		MOTOR WIND TUBE	CARTER MOTEUR	CÁRTER MOTOR
1	71	4 671 010 090		SCHRAUBE SELBSTSCHNEIDEN D	4x16	SELF-TAPPING SCREW	VIS DE FORAGE	TORNILLO PERFORADOR
1	72	1 671 620 010		MOTORABDECKUNG		MOTOR COVER	COUVERCLE MOTEUR	CUBIERTA DEL MOTOR
1	73	4 671 003 079		SCHRAUBE	M5x12	ST SCREW	VIS	TORNILLO
1	74	1 671 284 001		KABELDURCHFÜHRUNG		JACKET 2 OF CABLE CONNECTION	PASSE-FIL	BOQUILLA DE CAUCHO
1	75	1 671 001 730		HEBEL, ANTRIEB		LEVER, DRIVING	LEVIER TRACTION	PALANCA, CONDUCCIÓN
1	76	1 671 466 002		HALTER, RECHTS		BRACKET OF RIGHT STARTER	SUPPORT DROITE	SOPORTE DERECHO
1	77	2 671 391 001		SCHEIBE		WASHER	RONDELLE	ARANDELA
1	78	4 671 001 055		SCHRAUBE SELBSTSCHNEIDEN D	5x16	SELF-TAPPING SCREW	VIS DE FORAGE	TORNILLO PERFORADOR
1	79	1 671 466 001		HALTER, LINKS		BRACKET OF LEFT STARTER	SUPPORT GAUCHE	SOPORTE IZQ.
1	80	1 671 001 220		VERBINDUNGSKABEL		CONNECTION CABLE	CÂBLE DE RACCORDEMENT	CABLE DE CONEXIÓN
1	81	1 671 006 011		SCHRAUBE	M6x35	BOLT	VIS	TORNILLO
1	82	1 671 336 001		HALTERUNG		FIXED BRACKET	FIXATION	SOPORTE
1	83	1 671 005 016		6KT-MUTTER	M6	HEX. LOCK NUT	ECROU	TUERCA
1	84	1 671 657 001		VERBINDUNGSSTÜCK		CONNECTOR	PIÈCE DE JONCTION	PIEZA DE UNIÓN
1	85	1 671 001 442		HEBEL, MOTORBREMSE		LEVER, MOTOR BRAKE	LEVIER FREIN MOTEUR	PALANCA, FRENO MOTOR
1	86	1 671 121 801		BOWDENZUG, ANTRIEB	18"	BOWDEN CABLE, REAR DRIVE	CÂBLE BOWDEN, COMMANDE TRACTION	CABLE BOWDEN, UNIDAD TRASERA
1	87	2 671 002 033		SCHRAUBE	M4x8	TRIGGER BOLT	VIS	TORNILLO
1	88	1 671 178 001		GUMMITÜLLE		CORD PROTECTING SHEATH	PASSE-FIL	BOQUILLA DE CAUCHO
1	89	2 671 001 036		SCHRAUBE SELBSTSCHNEIDEN D	3x10	SELF-TAPPING SCREW	VIS DE FORAGE	TORNILLO PERFORADOR
1	90	2 671 011 124		FEDER		SPRING	RESSORT	MUELLE
1	91	1 671 279 005		STECKVERBINDUNG, LINKS		LEFT PLUG-IN OF HANDLE	CONNECTEUR, GAUCHE	CONEXIÓN, IZQ.
1	92	1 671 429 001		STECKVERBINDUNG, RECHTS		RIGHT PLUG-IN OF HANDLE	CONNECTEUR, DROITE	CONEXIÓN, DERECHA
1	93	1 671 257 001		GRIFFTRÄGER LINKS		LEFT HANDLE SUPPORT	SUPPORT DE POIGNÉE GAUCHE	SOPORTE DE ASA IZQUIERDO
1	94	1 671 257 002		GRIFFTRÄGER RECHTS		RIGHT HANDLE SUPPORT	SUPPORT DE POIGNÉE DROITE	SOPORTE DE ASA DERECHO
1	95	1 671 001 844		HOLM, OBERTEIL		HANDLE, UPPER PART	MANCHERON, PARTIE SUPERIEURE	MANILLAR, PARTE SUPERIOR
1	96	1 671 451 001		DRUCKPLATTE		PRESSURE PLATE	PLAQUE DE PRESSION	PLACA DE PRÉSION
1	97	1 671 001 071		SCHALTERGEHÄUSE, VORMONTAGE	EU (SCHUKO)	SWITCH BOX, LEFT ASSEMBLY	CARTER D'ASSEMBLAGE	CÁRTER DE MONTAJE
1	97	1 671 001 092		VERLÄNGERUNGSKABEL	10m (UK)	EXTENSION POWER CORD	CABLES DE RALLONGE	CABLE DE PROLOGACION

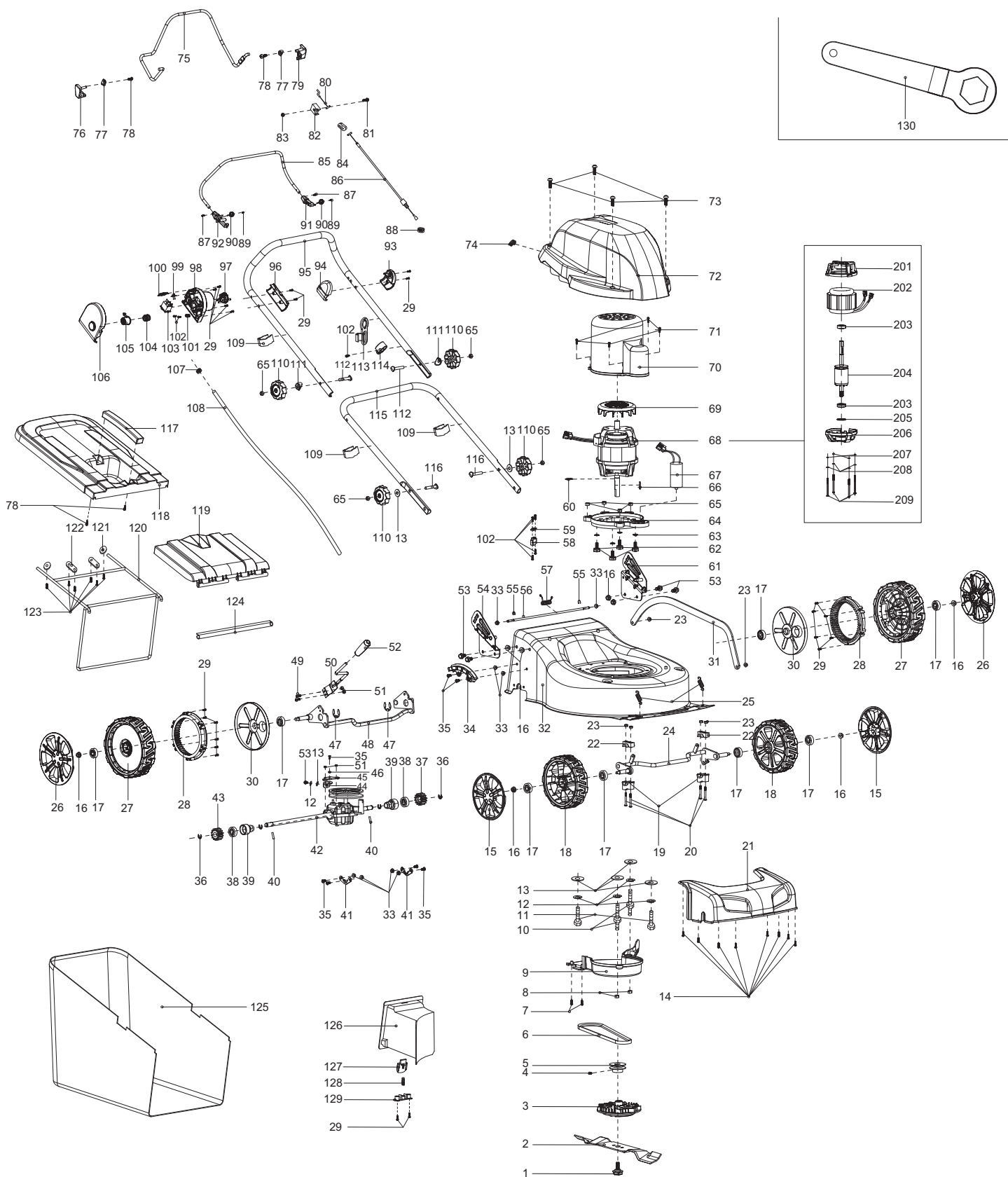

Seite / Page	Pos.	Teil-Nr. Part No. No. de pièce No. de pieza	Hinweise Notes Renseign. Nota	Bezeichnung	Spezifikation Specification	Description	Désignation	Denominación
1	98	1 671 001 071		SCHALTERGEHÄUS E, VORMONTAGE	EU (SCHUKO)	SWITCH BOX, LEFT ASSEMBLY	CARTER D'ASSEMBLAGE	CÁRTER DE MONTAJE
1	99	1 671 001 071		SCHALTERGEHÄUS E, VORMONTAGE	EU (SCHUKO)	SWITCH BOX, LEFT ASSEMBLY	CARTER D'ASSEMBLAGE	CÁRTER DE MONTAJE
1	100	1 671 001 043		LAMPENABDECKUN G		LAMPSHADE	ABAT-JOUR	PANTALLA
1	101	1 671 491 001		ZUGENTLASTUNG KABEL		STRAIN RELIEF CABLE	DÉCONTRACTION CÂBLE	CABLE DESCARGA DE TRACCIÓN
1	102	7 671 001 003		SCHRAUBE SELBSTSCHNEIDEN D	4x12	SELF-TAPPING SCREW	VIS DE FORAGE	TORNILLO PERFORADOR
1	103	1 671 010 040		SCHALTER		SWITCH	INTERRUPTEUR	INTERRUPTOR
1	104	1 671 011 079		FEDER		SPRING OF SAFETY BUTTON	RESSORT	MUELLE
1	105	1 671 425 002		SICHERHEITSTASTE		SAFETY BUTTON	BOUCHON	BOTÓN
1	106	1 671 452 001		SCHALTERGEHÄUS E, RECHTS		SWITCH BOX, RIGHT	CARTER	CÁRTER
1	107	1 671 283 001		KABELDURCHFÜHR UNG		JACKET 1 OF CABLE CONNECTION	PASSE-FIL	BOQUILLA DE CAUCHO
1	108	1 671 052 410		VERBINDUNGSKABE L MIT ANSCHLUßKLEMME N, SATZ	1500mm	CONNECTION CABLE WITH TERMINALS, SET	CÂBLE DE RACCORDEMENT, JEU	CABLE DE CONEXIÓN, JUEGO
1	109	3 671 177 001		KABELCLIPP		CABLE CLIP	CLIP DE CÂBLE	CLIP PARA CABLE
1	110	4 671 453 001		STERNGRIF		STAR KNOB	MANETTE	MANIJA DE ESTRELLA
1	111	2 671 001 085		SCHEIBE		WASHER	RONDELLE	ARANDELA
1	112	2 671 006 004		FLACHKOPFSCHRA UBE	M8x52	FLAT HEAD BOLT	VIS À TÊTE CYLINDRIQUE	TORNILLO DE CABEZA PLANA
1	113	1 671 479 001	2010-05 =>	KABELHALTERUNG	Øi=26	CABLE HOLDER	ATTACHE POUR CÂBLES	SOPORTE DE CABLES
1	114	1 671 800 102	2010-05 =>	KLEMMSCHELLE	Øi=24	BLOCK RING	COLLIER DE SERRAGE	ABRAZADERA DE SUJECIÓN
1	115	1 671 001 445		HOLM, UNTERTEIL		HANDLE, LOWER PART	MANCHERON, PARTIE INFÉRIEURE	MANILLAR, PARTE INFERIOR
1	116	2 671 006 118		FLACHKOPFSCHRA UBE	M8x35	FLAT HEAD BOLT	VIS À TÊTE CYLINDRIQUE	TORNILLO DE CABEZA PLANA
1	117	1 671 454 001		HANDGRIF		HANDLE OF GRASS CATCHER	POIGNÉE	MANGO
1	118	1 671 467 001		KORB, OBERTEIL		GRASS-BOX, UPPER	SAC, PARTIE	CESTO, SUPERIOR
1	119	1 671 468 001		HECKKLAPPE		REAR COVER BOARD	HAYON	PORTÓN TRASERO
1	120	1 671 001 443		RAHMEN		GRASS CATCHER BRACKET	CADRE	MARKO
1	121	2 671 001 436		SCHEIBE	φ5xφ24x2	TIGHTEN PRESSING PLATE	RONDELLE	ARANDELA
1	122	2 671 001 203		DRUCKPLATTE		PRESSURE PLATE	PLAQUE DE PRESSION	PLACA DE PRÉSION
1	123	6 671 001 054		SCHRAUBE SELBSTSCHNEIDEN D	5x12	SELF-TAPPING SCREW	VIS DE FORAGE	TORNILLO PERFORADOR
1	124	1 671 001 353		DRUCKLEISTE		PRESSING BAR	BARRE	LISTÓN
1	125	1 671 001 418		NYLONEINSATZ FÜR FANGKORB	60L Nylon, Makita logo	GRASS CATCHER	SAC	CESTO
1	126	1 671 660 001		MULCHEINSATZ	with edge cutting	MULCHING BLOCK	INSERT MULCH	TAPA
1	127	1 671 316 004		VERRIEGELUNGSKN OPF	20"	LOCKING BUTTON	TÊTE DE VERROUILLAGE	BOTÓN DE BLOQUEO
1	128	1 671 011 005		FEDER	φ8,0xφ0,9x31mm	SPRING	RESSORT	MUELLE
1	129	1 671 317 001		DRUCKPLATTE		PRESSURE PLATE	PLAQUE DE PRESSION	PLACA DE PRÉSION
1	130	1 671 002 009		RINGSCHLÜSSEL		BOX SPANNER	CLÉ POLYGONALE	LLAVE DE ESTRÍAS
1	201	1 671 001 131		MOTORABDECKUNG OBEN		MOTOR COVER UPPER	COUVERCLE MOTEUR EN HAUT	CUBIERTA DEL MOTOR ARRIVA
1	202	1 671 001 012		STATOR		STATOR	STATOR	ESTATOR

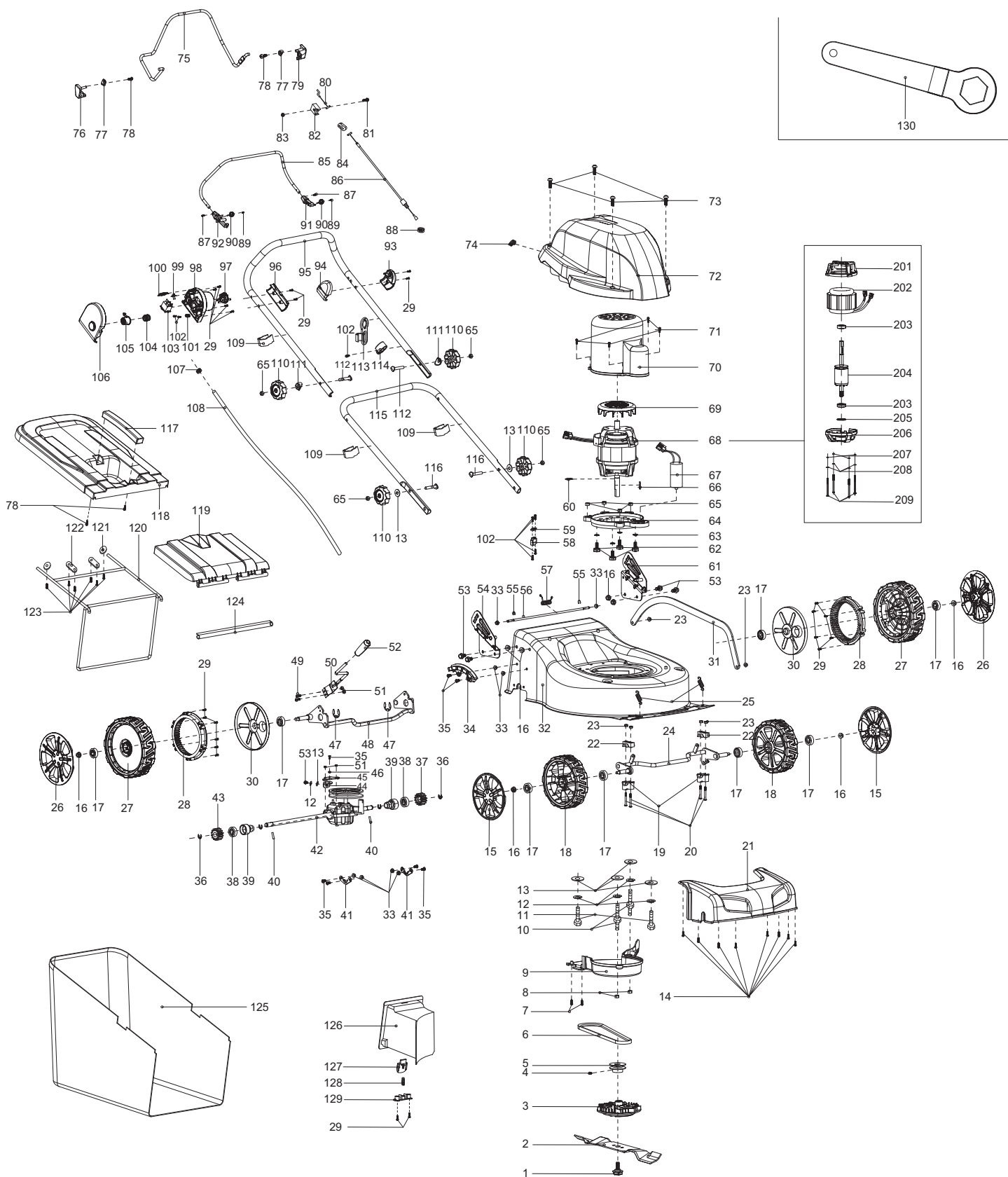

ELM4611 (2012)

1

EM-460 S, ELM4611 (SCHUKO, UK)  
 EM-460 S, ELM4611 (SCHUKO, UK)  
 EM-460 S, ELM4611 (SCHUKO, UK)  
 EM-460 S, ELM4611 (SCHUKO, UK)



Seite / Page	Pos.	ELM4611 (2012)	Teil-Nr. Part No. No. de pièce No. de pieza	Hinweise Notes Renseign. Nota	Bezeichnung	Spezifikation Specification	Description	Désignation	Denominación
1	203	2	671 004 056		KUGELLAGER		BALL BEARING	ROULEMENT À BILLES	RODAMIENTO DE BOLAS
1	204	1	671 002 011		ROTOR		ROTOR	ROTOR	ROTOR
1	205	1	671 007 078		WELLENSCHEIBE		WAVE WASHER	RONDELLE	ARANDELA
1	206	1	671 001 132		MOTORABDECKUNG UNTEN		MOTOR COVER LOWER	COUVERCLE MOTEUR EN BAS	CUBIERTA DEL MOTOR ABAJO
1	207	4	671 007 054		FLACHSCHEIBE		FLAT WASHER	RONDELLE PLATE	ARANDELA
1	208	4	671 008 004		FEDERSCHEIBE	φ5	SPRING WASHER	RONDELLE A RESSORT	ARANDELA ELASTICO
1	209	4	671 002 039		SCHRAUBE		TRIGGER SCREW	VIS	TORNILLO

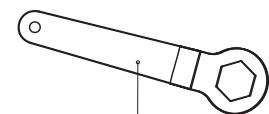

131

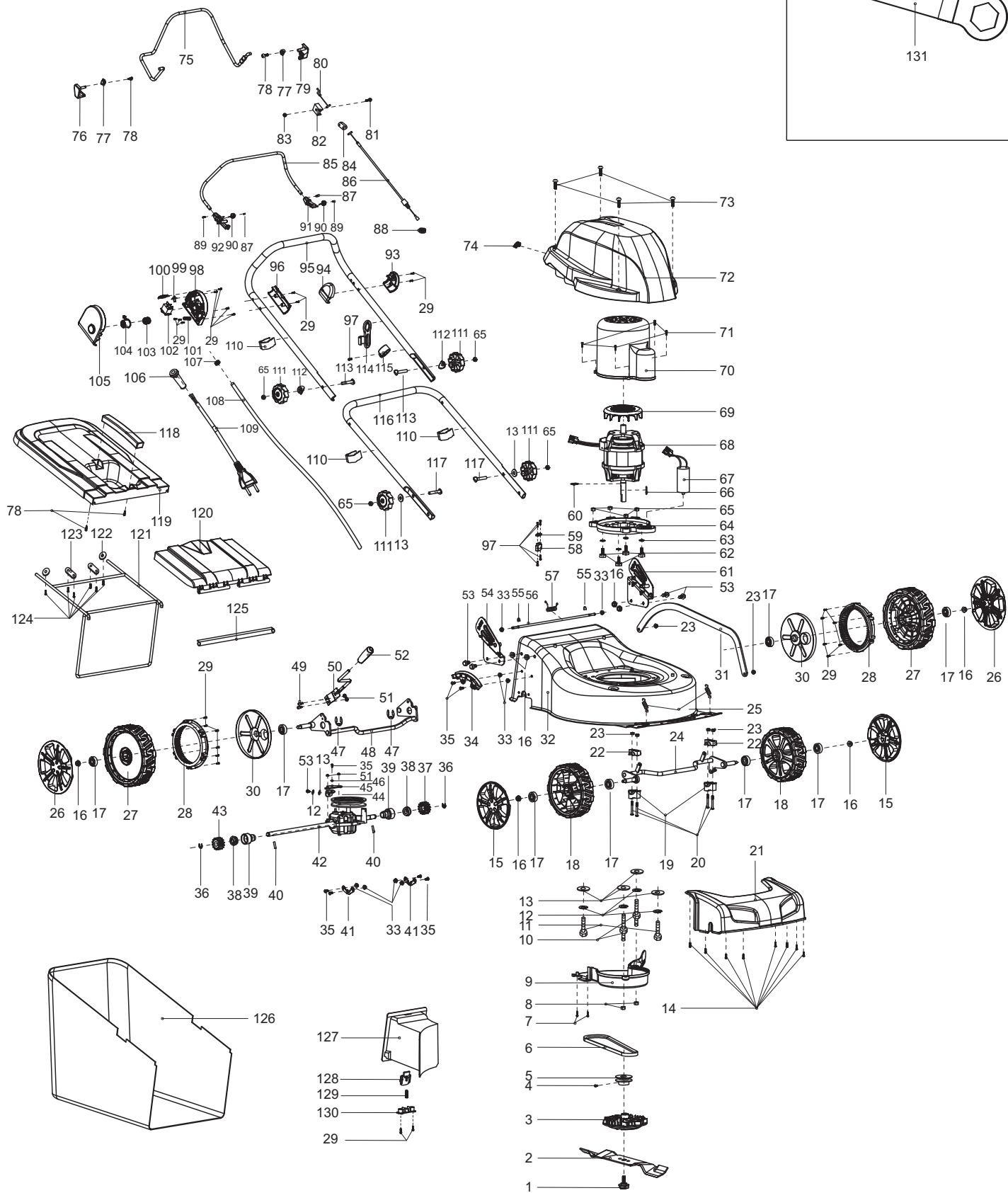

Seite / Page	Pos.	ELM4611 (2012)	Teil-Nr. Part No. No. de pièce No. de pieza	Hinweise Notes Renseign. Nota	Bezeichnung	Spezifikation Specification	Description	Désignation	Denominación
2	1	1	671 100 802		MESSERSCHRAUBE	M10x1.35x40	BLADE TIGHTEN BOLT	VIS DE LAME	TORNILLO DE LA CUCHILLA
2	2	1	671 146 102		MESSER	460X55X3mm	BLADE	LAME	CUCHILLA
2	3	1	671 005 057		MESSERHALTER		HUB	MOYEU	SOPORTE DE LA CUCHILLA
2	4	1	671 030 050		6KT-SCHRAUBE	M6x8	HEXAGON HEAD BOLT	VIS À SIX PANS	TORNILLO HEXAGONAL
2	5	1	671 004 009		RIEMENSCHLEIBE	45	PULLEY	POULIE À GORGE POUR COURROIE	DISCO DE LA CORREA
2	6	1	671 002 043		KEILRIEMEN	Li=752mm, La=790mm	V-BELT	COURROIE TRAPÉZOIDALE	CORREA TRAPEZOIDAL
2	7	2	671 001 037		SCHRAUBE SELBSTSCHNEIDEN D	5x16	SELF-TAPPING SCREW	VIS DE FORAGE	TORNILLO PERFORADOR
2	8	2	671 005 008		6KT-MUTTER	M8	HEXAGONAL LOCKING NUT	ECROU HEXAGONAL	TUERCA HEXAGONAL
2	9	1	671 658 001		RIEMENABDECKUNG	with edge cutting	BELT COVER	COUVERCLE DE COURROIE	CUBIERTA DE CORREA
2	10	2	671 003 044		SPEZIALSCHRAUBE	M8x17x35	SPECIAL SCREW	VIS SPÉCIALE	TORNILLO ESPECIAL
2	11	2	671 006 017		6KT-SCHRAUBE	M8x30	HEXAGON HEAD BOLT	VIS À SIX PANS	TORNILLO HEXAGONAL
2	12	5	671 008 002		FEDERRING	φ8	SPRING RING	RONDELLE À RESSORT	ANILLO ELÁSTICO
2	13	7	671 007 007		SCHEIBE	φ8	WASHER	RONDELLE	ARANDELA
2	14	8	671 001 062		SCHRAUBE SELBSTSCHNEIDEN D	4,2x10	SELF-TAPPING SCREW	VIS DE FORAGE	TORNILLO PERFORADOR
2	15	2	671 001 176		RADKAPPE	7"	WHEEL COVER	CHAPEAU DE MOYEU	CAPERUZA DE RUEDA
2	16	8	671 005 028		6KT-MUTTER	M8	HEXAGONAL LOCKING NUT	ECROU HEXAGONAL	TUERCA HEXAGONAL
2	17	8	671 004 012		KUGELLAGER	6201Z	BALL BEARING	ROULEMENT À BILLES	RODAMIENTO DE BOLAS
2	18	2	671 002 012		RAD	7"	WHEEL ASSY.	ROUE	RUEDA
2	19	2	671 418 001		LAGERSCHALE		FIXED BRACKET	COUILLE DE COUSSINET	MITAD DE RODAMIENTO
2	20	4	671 002 028		SCHRAUBE	M6x45	TRIGGER BOLT	VIS	TORNILLO
2	21	1	671 659 001		FRONTTEIL	BLACK with edge cutting	FRONT COVER	PANNEAU	FRONTAL CUBIERTA
2	22	2	671 445 001		LAGERSCHALE		AXLE SHEATH	PLAQUETTE	COJINETE
2	23	6	671 005 005		6KT-MUTTER	M6	LOCKING NUT	ECROU	TUERCA
2	24	1	671 001 786		VORDERACHSE	with edge cutting	FRONT WHEEL AXLE	ESSIEU AVANT	EJE DELANTERO
2	25	2	671 011 125		ZUGFEDER		EXTENSION SPRING OF FRONT WHEEL AXLE	RESSORT	RESORTE
2	26	2	671 001 177		RADKAPPE	8"	WHEEL COVER	CHAPEAU DE MOYEU	CAPERUZA DE RUEDA
2	27	2	671 020 140		RAD	8"	WHEEL ASSY.	ROUE	RUEDA
2	28	2	671 464 001		ZAHNRAD		TEETH RING	ROUE DENTEE	PIÑÓN
2	29	25	671 001 005		SCHRAUBE SELBSTSCHNEIDEN D	4x16	SELF-TAPPING SCREW	VIS DE FORAGE	TORNILLO PERFORADOR
2	30	2	671 001 176		RADKAPPE	7"	WHEEL COVER	CHAPEAU DE MOYEU	CAPERUZA DE RUEDA
2	31	1	671 002 671		VERBINDUNGSSTANGE		CONNECTING ROD	BARRE DE RACCORDEMENT	BARRA DE CONEXIÓN
2	32	1	671 001 527		GEHÄUSE BLAU	18" with edge cutting	DECK BLUE	CHÂSSIS BLEU	CAJA AZUL
2	33	8	671 005 024		6KT-MUTTER	M6	HEXAGONAL LOCKING NUT	ECROU HEXAGONAL	TUERCA HEXAGONAL
2	34	1	671 001 018		DREHPUNKT FÜR HÖHENVERSTELLUNG		HEIGHT ADJUSTMENT PLATE	POINT DE ROTATION POUR LE RÉGLAGE EN HAUTEUR	PUNTO DE GIRO PARA REGLAJE DE ALTURA
2	35	7	671 002 019		SCHRAUBE	M6x12	TRIGGER BOLT	VIS	TORNILLO

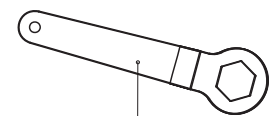

131

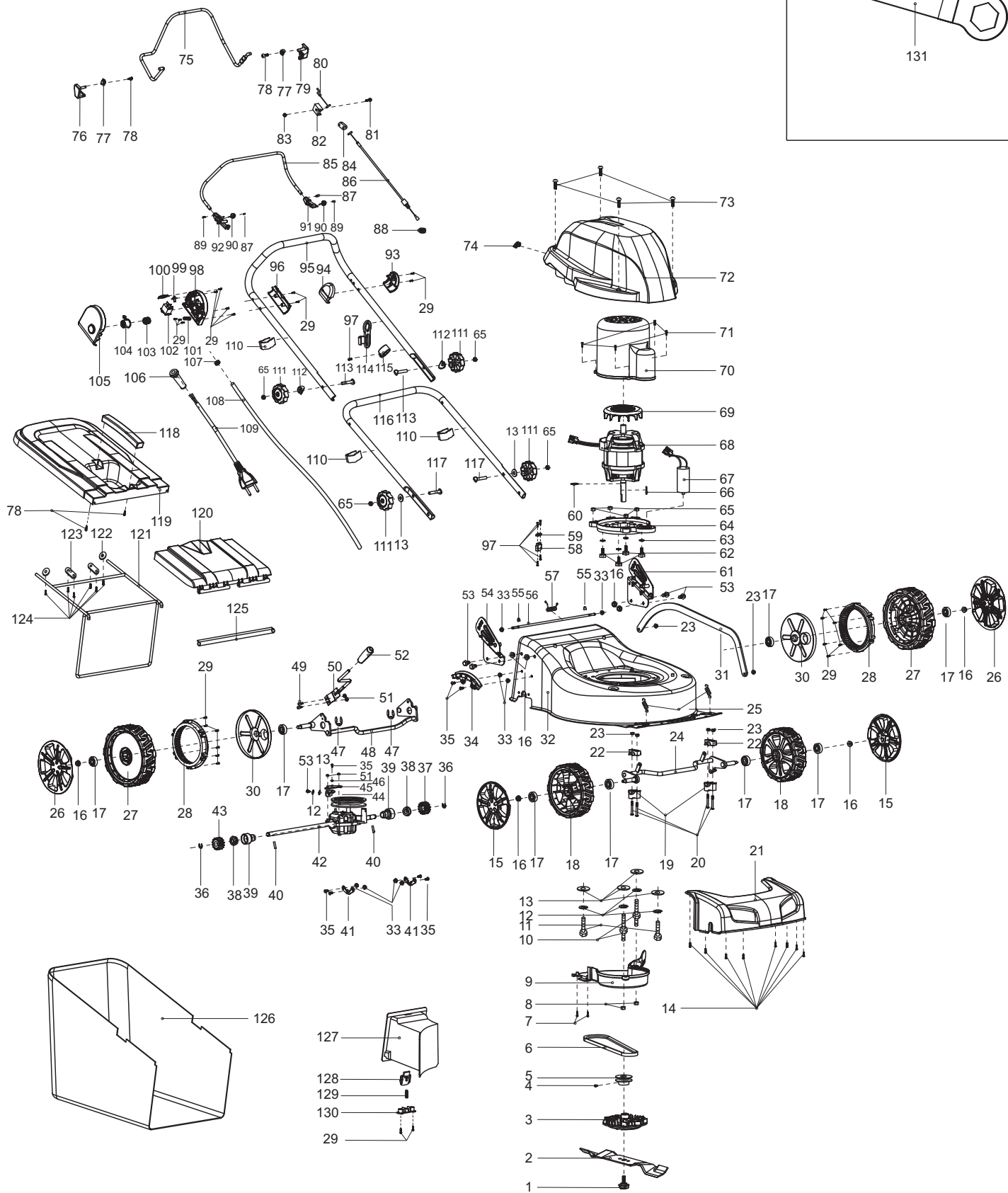

Seite / Page	Pos.	Teil-Nr. Part No. No. de pièce No. de pieza	Hinweise Notes Renseign. Nota	Bezeichnung	Spezifikation Specification	Description	Désignation	Denominación
2	36	4 671 090 020		SICHERUNGSSCHEIBE		SAFETY WASHER	RONDELLE SÉCURITÉ	ARANDELA SEGURIDAD
2	37	1 671 003 001		ZAHNRAD, LINKS		GEAR WHEEL, LEFT	ROUE DENTÉE, GAUCHE	PIÑÓN, IZQ.
2	38	2 671 004 023		LAGER		BEARING	ROULEMENT	RODAMIENTO
2	39	2 671 002 035		LAGERGEHÄUSE		BEARING HOUSING	CARTER	CÁRTER
2	40	2 671 090 001		ZYLINDERSTIFT	φ5x21.5	CYLINDRICAL PIN	GOUPILLE CYLINDRIQUE	PASADOR CILINDRICO
2	41	2 671 001 244		FIXIERUNG		RING OF AXLE FIXING	FIXATION	FIJACIÓN
2	42	1 671 502 016		ANTRIEB	self-propelled, with edge cutting	GEAR BOX	GROUPE TRACTION	UNIDAD DE TRACCIÓN
2	43	1 671 003 002		ZAHNRAD, RECHTS		RIGHT GEAR	ROUE DENTÉE, DROITE	PIÑÓN, DERECHA
2	44	1 671 001 521		BEFESTIGUNGSBLECH	2	FIXING PLATE	TÔLE DE FIXATION	CHAPA DE FIJACIÓN
2	45	1 671 001 460		BEFESTIGUNGSBLECH		FIXING PLATE	TÔLE DE FIXATION	CHAPA DE FIJACIÓN
2	46	1 671 008 003		FEDERSCHEIBE	φ6,65	SPRING WASHER	RONDELLE A RESSORT	ARANDELA ELASTICO
2	47	2 671 009 003		SICHERUNGSSCHEIBE	φ19x1.5	SAFETY WASHER	RONDELLE SÉCURITÉ	ARANDELA SEGURIDAD
2	48	1 671 144 602		HINTERRADACHSE KPL.	with edge cutting	REAR AXLE ASSY.	ESSIEU ARRIÈRE CPL.	EJE TRASERO CPL.
2	49	2 671 002 029		SCHRAUBE	M5x12	TRIGGER BOLT	VIS	TORNILLO
2	50	1 671 102 602		HEBEL, HÖHENVERSTELLUNG UND GRIFFUMHÜLLUNG KPL.		LEVER, HEIGHT ADJUSTMENT CPL.	LEVIER, REGLAGE HAUTEUR CPL.	PALANCA, AJUSTE ALTURA CPL.
2	51	4 671 005 011		6KT-MUTTER	M5	HEXAGONAL LOCKING NUT	ECROU HEXAGONAL	TUERCA HEXAGONAL
2	52	1 671 102 602		HEBEL, HÖHENVERSTELLUNG UND GRIFFUMHÜLLUNG KPL.		LEVER, HEIGHT ADJUSTMENT CPL.	LEVIER, REGLAGE HAUTEUR CPL.	PALANCA, AJUSTE ALTURA CPL.
2	53	5 671 006 064		6KT-SCHRAUBE	M8x6	HEXAGON HEAD BOLT	VIS À SIX PANS	TORNILLO HEXAGONAL
2	54	1 671 001 180		GRIFFANBINDUNG, RECHTS	MAKITA BLUE	BRACKET HANDLE, RIGHT	BRIDE DE POIGNÉE, DROITE	FIJACIÓN DE MANGO, DERECHA
2	55	2 671 009 017		KLEMMRING		OPEN BLOCK RING	ANNEAU	ANILLO
2	56	1 671 001 518		STANGE GRASKLAPPE		LONG POLE	TRINGLE TRAPPE À HERBE	BARRA TAPA DE YERBA
2	57	1 671 011 101		FEDER		SPRING OF REAR COVER BOARD	RESSORT	MUELLE
2	58	1 671 260 001		KABELKLEMME		CABLE HOLDER	CRAMP	COLLIER DE SERRAGE
2	59	1 671 010 230		KABELKLEMME		CABLE HOLDER	CRAMP	COLLIER DE SERRAGE
2	60	1 671 009 019		SICHERUNGSRING		SNAP RING	CIRCLIP	ANILLO SEGURIDAD
2	61	1 671 001 179		GRIFFANBINDUNG, LINKS	MAKITA BLUE	BRACKET HANDLE, LEFT	BRIDE DE POIGNÉE, GAUCHE	FIJACIÓN DE MANGO, IZQ.
2	62	4 671 001 009		SCHRAUBE		MOTOR TIGHTEN BOLT	VIS	TORNILLO
2	63	4 671 080 100		ZACKENRING		TOOTHED WASHER	RONDELLE DENTÉE	ARANDELA DENTADA
2	64	1 671 600 012		MOTORTRÄGER		MOTOR BRACKET	SUPPORT DE MOTEUR	SOPORTE DE MOTOR
2	65	8 671 005 023		6KT-MUTTER	M8	HEXAGONAL NUT	ECROU HEXAGONAL	TUERCA HEXAGONAL
2	66	1 671 090 037		PASSFEDER		FLAT KEY	CLAVETTE	CHAVETA
2	67	1 671 003 046		KONDENSATOR	45µF	CAPACITOR	CONDENSATEUR	CONDENSADOR

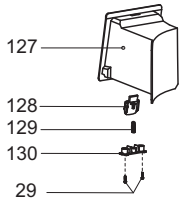
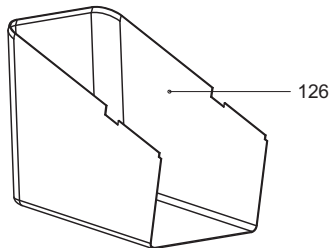
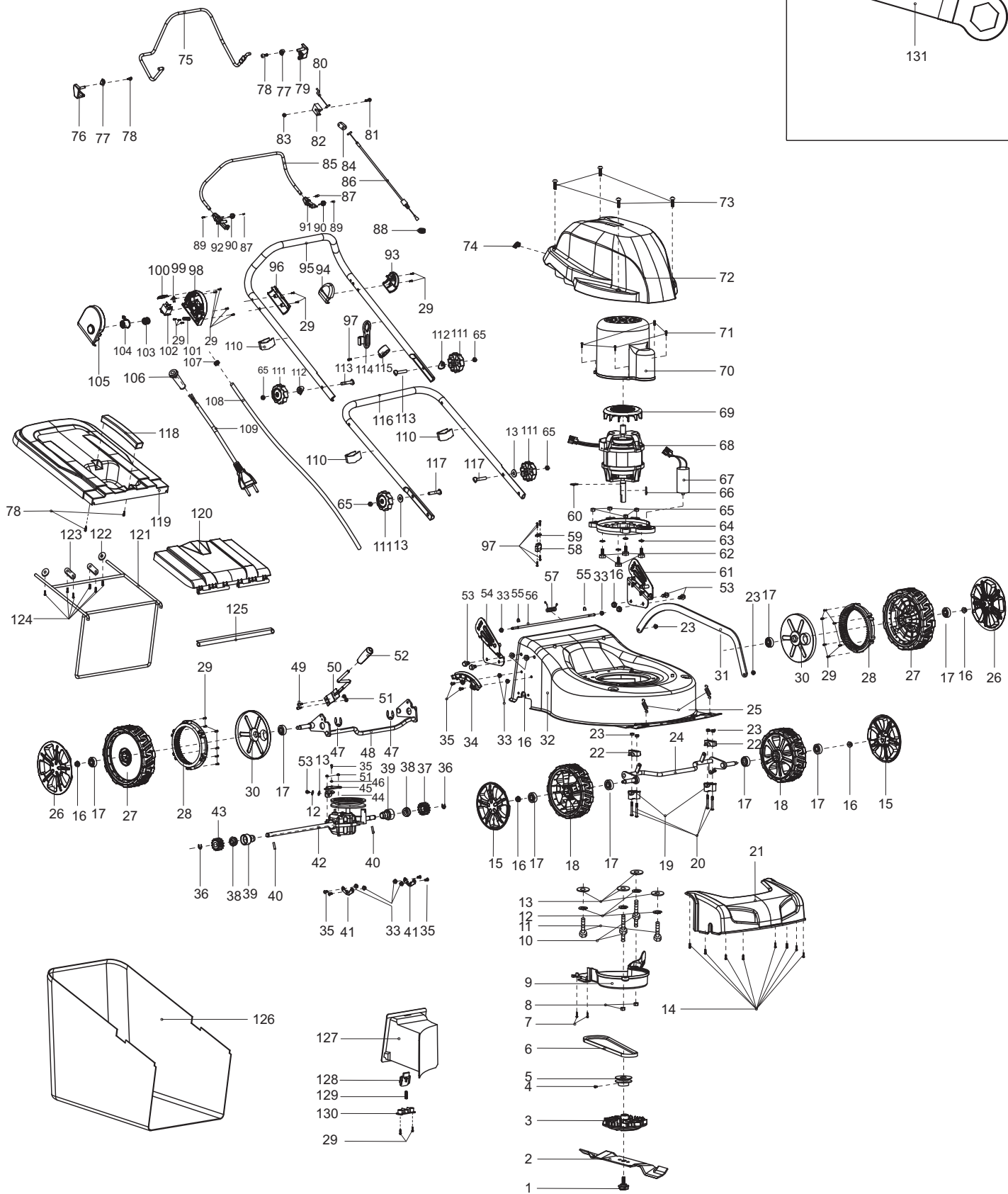
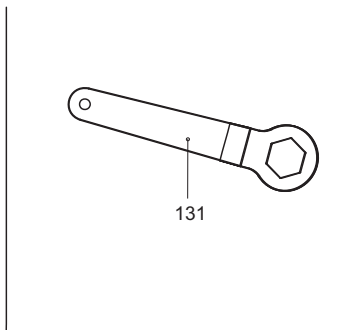

Seite / Page	Pos.	Teil-Nr. Part No. No. de pièce No. de pieza	Hinweise Notes Renseign. Nota	Bezeichnung	Spezifikation Specification	Description	Désignation	Denominación
2	68	1 671 002 023		MOTOR	220V~60Hz,1800 W	MOTOR	MOTEUR	MOTOR
2	69	1 671 327 001		LÜFTERRAD		FAN	ROUE DE VENTILATEUR	RODETE DEL VENTILADOR
2	70	1 671 610 010		MOTORGEHÄUSE		MOTOR WIND TUBE	CARTER MOTEUR	CÁRTER MOTOR
2	71	4 671 010 090		SCHRAUBE SELBSTSCHNEIDEN D	4x16	SELF-TAPPING SCREW	VIS DE FORAGE	TORNILLO PERFORADOR
2	72	1 671 200 103		MOTORABDECKUNG		MOTOR COVER	COUVERCLE MOTEUR	CUBIERTA DEL MOTOR
2	73	4 671 003 079		SCHRAUBE	M5x12	ST SCREW	VIS	TORNILLO
2	74	1 671 284 001		KABELDURCHFÜHR UNG		JACKET 2 OF CABLE CONNECTION	PASSE-FIL	BOQUILLA DE CAUCHO
2	75	1 671 001 623		HEBEL, ANTRIEB		LEVER, DRIVING	LEVIER TRACTION	PALANCA, CONDUCCIÓN
2	76	1 671 466 002		HALTER, RECHTS		BRACKET OF RIGHT STARTER	SUPPORT DROITE	SOPORTE DERECHO
2	77	2 671 391 001		SCHEIBE		WASHER	RONDELLE	ARANDELA
2	78	4 671 105 502		SCHRAUBE SELBSTSCHNEIDEN D	5x16	SELF-TAPPING SCREW	VIS DE FORAGE	TORNILLO PERFORADOR
2	79	1 671 466 001		HALTER, LINKS		BRACKET OF LEFT STARTER	SUPPORT GAUCHE	SOPORTE IZQ.
2	80	1 671 001 220		VERBINDUNGSKABE L		CONNECTION CABLE	CÂBLE DE RACCORDEMENT	CABLE DE CONEXIÓN
2	81	1 671 006 011		SCHRAUBE	M6x35	BOLT	VIS	TORNILLO
2	82	1 671 336 001		HALTERUNG		FIXED BRACKET	FIXATION	SOPORTE
2	83	1 671 050 160		6KT-MUTTER	M6	HEXAGONAL LOCKING NUT	ECROU HEXAGONAL	TUERCA HEXAGONAL
2	84	1 671 657 001		VERBINDUNGSSTÜC K		CONNECTOR	PIÈCE DE JONCTION	PIEZA DE UNIÓN
2	85	1 671 001 622		HEBEL, MOTORBREMSE		LEVER, MOTOR BRAKE	LEVIER FREIN MOTEUR	PALANCA, FRENO MOTOR
2	86	1 671 121 801		BOWDENZUG, ANTRIEB	18"	BOWDEN CABLE, REAR DRIVE	CÂBLE BOWDEN, COMMANDE TRACTION	CABLE BOWDEN, UNIDAD TRASERA
2	87	2 671 002 033		SCHRAUBE	M4x8	TRIGGER BOLT	VIS	TORNILLO
2	88	1 671 780 010		GUMMITÜLLE		CORD PROTECTING SHEATH	PASSE-FIL	BOQUILLA DE CAUCHO
2	89	2 671 001 036		SCHRAUBE SELBSTSCHNEIDEN D	3x10	SELF-TAPPING SCREW	VIS DE FORAGE	TORNILLO PERFORADOR
2	90	2 671 011 124		FEDER		SPRING	RESSORT	MUELLE
2	91	1 671 279 005		STECKVERBINDUNG, LINKS		LEFT PLUG-IN OF HANDLE	CONNECTEUR, GAUCHE	CONEXIÓN, IZQ.
2	92	1 671 290 010		STECKVERBINDUNG, RECHTS		RIGHT PLUG-IN OF HANDLE	CONNECTEUR, DROITE	CONEXIÓN, DERECHA
2	93	1 671 570 010		GRIFFTRÄGER LINKS		LEFT HANDLE SUPPORT	SUPPORT DE POIGNÉE GAUCHE	SOPORTE DE ASA IZQUIERDO
2	94	1 671 570 020		GRIFFTRÄGER RECHTS		RIGHT HANDLE SUPPORT	SUPPORT DE POIGNÉE DROITE	SOPORTE DE ASA DERECHO
2	95	1 671 001 618		HOLM, OBERTEIL		HANDLE, UPPER PART	MANCHERON, PARTIE SUPERIEURE	MANILLAR, PARTE SUPERIOR
2	96	1 671 451 001		DRUCKPLATTE		PRESSURE PLATE	PLAQUE DE PRESSION	PLACA DE PRÉSION
2	97	5 671 001 003		SCHRAUBE SELBSTSCHNEIDEN D	4x12	SELF-TAPPING SCREW	VIS DE FORAGE	TORNILLO PERFORADOR
2	98	1 671 635 002		SCHALTERGEHÄUSE , LINKS		SWITCH BOX, LEFT	CARTER	CÁRTER
2	99	1 671 005 259		KABEL MIT STECKER, SATZ		CABLE WITH PLUG, SET	CABLE AVEC PRISE, JEU	CABLE CON ENCHUFE, JUNTA

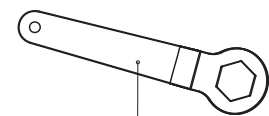

131

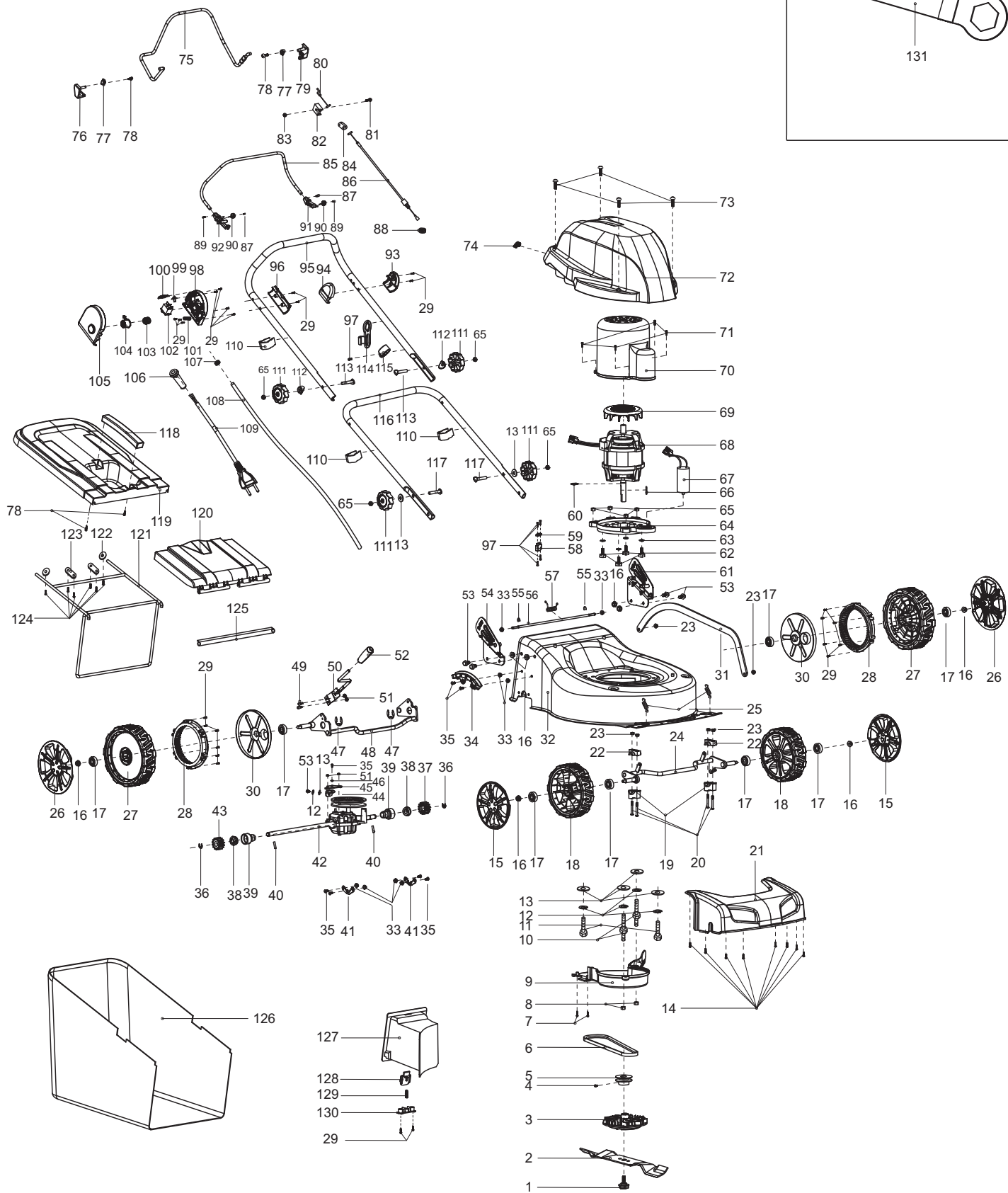

Seite / Page	Pos.	ELM4611 (2012)	Teil-Nr. Part No. No. de pièce No. de pieza	Hinweise Notes Renseign. Nota	Bezeichnung	Spezifikation Specification	Description	Désignation	Denominación
2	100	1	671 001 043		LAMPENABDECKUNG		LAMPSHADE	ABAT-JOUR	PANTALLA
2	101	1	671 263 001		ZUGENTLASTUNG		CABLE PRESSING PLATE	DÉCONTRACTION	DESCARGA DE TRACCIÓN
2	102	1	671 010 040		SCHALTER		SWITCH	INTERRUPTEUR	INTERRUPTOR
2	103	1	671 011 079		FEDER		SPRING OF SAFETY BUTTON	RESSORT	MUELLE
2	104	1	671 425 002		SICHERHEITSTASTE		SAFETY BUTTON	BOUCHON	BOTÓN
2	105	1	671 635 001		SCHALTERGEHÄUSE , RECHTS		SWITCH BOX, RIGHT	CARTER	CÁRTER
2	106	1	671 005 259		KABEL MIT STECKER, SATZ		CABLE WITH PLUG, SET	CABLE AVEC PRISE, JEU	CABLE CON ENCHUFE, JUNTA
2	107	1	671 283 001		KABELDURCHFÜHR UNG		JACKET 1 OF CABLE CONNECTION	PASSE-FIL	BOQUILLA DE CAUCHO
2	108	1	671 005 245		VERBINDUNGSKABE L MIT ANSCHLUßKLEMME N, SATZ		CONNECTION CABLE WITH TERMINALS, SET	CÂBLE DE RACCORDEMENT, JEU	CABLE DE CONEXIÓN, JUEGO
2	109	1	671 005 259		KABEL MIT STECKER, SATZ		CABLE WITH PLUG, SET	CABLE AVEC PRISE, JEU	CABLE CON ENCHUFE, JUNTA
2	110	3	671 611 001		BOWDENZUGHALTE R		BOWDEN CABLE CLAMP	COLLIER DE SERRANGE	SOPORTE DE CABLE BOWDEN
2	111	4	671 530 010		STERNGRIFF		STAR KNOB	MANETTE	MANIJA DE ESTRELLA
2	112	2	671 001 085		SCHEIBE		WASHER	RONDELLE	ARANDELA
2	113	2	671 061 650		FLACHKOPFSCHRAU BE	M8x58	FLAT HEAD BOLT	VIS À TÊTE CYLINDRIQUE	TORNILLO DE CABEZA PLANA
2	114	1	671 479 001		KABELHALTERUNG	Øi=26	CABLE HOLDER	ATTACHE POUR CÂBLES	SOPORTE DE CABLES
2	115	1	671 800 102		KLEMMSCHELLE	Øi=24	BLOCK RING	COLLIER DE SERRAGE	ABRAZADERA DE SUJECIÓN
2	116	1	671 001 619		HOLM, UNTERTEIL		HANDLE, LOWER PART	MANCHERON, PARTIE INFÉRIEURE	MANILLAR, PARTE INFERIOR
2	117	2	671 006 118		FLACHKOPFSCHRAU BE	M8x35	FLAT HEAD BOLT	VIS À TÊTE CYLINDRIQUE	TORNILLO DE CABEZA PLANA
2	118	1	671 454 001		HANDGRIFF		HANDLE OF GRASS CATCHER	POIGNÉE	MANGO
2	119	1	671 467 001		KORB, OBERTEIL		GRASS-BOX, UPPER	SAC, PARTIE	CESTO, SUPERIOR
2	120	1	671 468 001		HECKKLAPPE		REAR COVER BOARD	HAYON	PORTÓN TRASERO
2	121	1	671 001 443		RAHMEN		GRASS CATCHER BRACKET	CADRE	MARKO
2	122	2	671 001 436		SCHEIBE	φ5xφ24x2	TIGHTEN PRESSING PLATE	RONDELLE	ARANDELA
2	123	2	671 001 203		DRUCKPLATTE		PRESSURE PLATE	PLAQUE DE PRESSION	PLACA DE PRÉSION
2	124	6	671 001 054		SCHRAUBE SELBSTSCHNEIDEN D	5x12	SELF-TAPPING SCREW	VIS DE FORAGE	TORNILLO PERFORADOR
2	125	1	671 001 353		DRUCKLEISTE		PRESSING BAR	BARRE	LISTÓN
2	126	1	671 001 418		NYLONEINSATZ FÜR FANGKORB	60L Nylon, Makita logo	GRASS CATCHER	SAC	CESTO
2	127	1	671 660 001		MULCHEINSATZ	with edge cutting	MULCHING BLOCK	INSERT MULCH	TAPA
2	128	1	671 316 004		VERRIEGELUNGSKN OPF	20"	LOCKING BUTTON	TÊTE DE VERROUILLAGE	BOTÓN DE BLOQUEO
2	129	1	671 011 005		FEDER	φ8,0xφ0,9x31mm	SPRING	RESSORT	MUELLE
2	130	1	671 317 001		DRUCKPLATTE		PRESSURE PLATE	PLAQUE DE PRESSION	PLACA DE PRÉSION
2	131	1	671 002 009		RINGSCHLÜSSEL		BOX SPANNER	CLÉ POLYGONALE	LLAVE DE ESTRÍAS

1

EM-460 S, ELM4611 (SCHUKO, UK)  
 EM-460 S, ELM4611 (SCHUKO, UK)  
 EM-460 S, ELM4611 (SCHUKO, UK)  
 EM-460 S, ELM4611 (SCHUKO, UK)

2

ELM4611 (BRAZIL)  
 ELM4611 (BRAZIL)  
 ELM4611 (BRAZIL)  
 ELM4611 (BRAZIL)

	Zeichenerklärung	Key to symbols
=> 1999999 2000000 => 2003.04 => TI 2003/07 Acc. = { m Corr.	Produktion bis Serien-Nr. Neues Teil ab Serien-Nr. Neues Teil ab Jahr / Monat Siehe Technische Information Jahr / Nr. Zubehör (nicht im Lieferumfang) Keine Serienausführung, jedoch verwendbar Beinhaltet Positions-Nr. Meterware Druckfehlerberichtigung	Production to serial number New part from serial number New part from Year / Month See Technical Information Year / No. Accessories (not included in the delivery inventory) No standard execution, may be used Contains item number Sold by the meter Error correction
	Änderungen vorbehalten	Specifications subject to change without notice
	Légende	Explicación de símbolos
=> 1999999 2000000 => 2003.04 => TI 2003/07 Acc. = { m Corr.	Production jusqu'à n° de série Nouvelle pièce à partir du n° de série Nouvelle pièce à partir de année / mois Voir information technique année / n° Accessoires (non compris dans la livraison) Aucune exécut. en série, cependant utilisable contient n° de numéro Au mètre Rectification d'erreurs	Producción hasta N° de serie Pieza nueva a partir de N° de serie Pieza nueva a partir de año / mes Véase inform. técnico año / N° Accesorios (no incluido en la extensión del suministro) No es de serie, pero sirve Contiene pos N° Por metro Fe de erratas
	Changements sans préavis	Mejoras constructivas sin previo aviso